

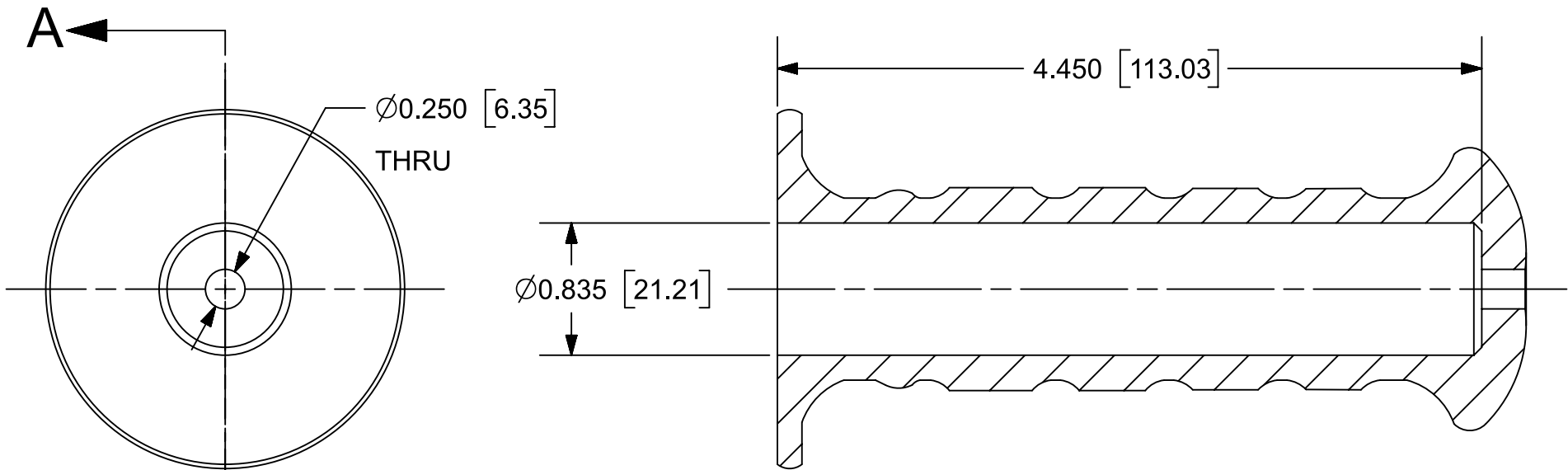

REV	DESCRIPTION	DATE	BY	APP

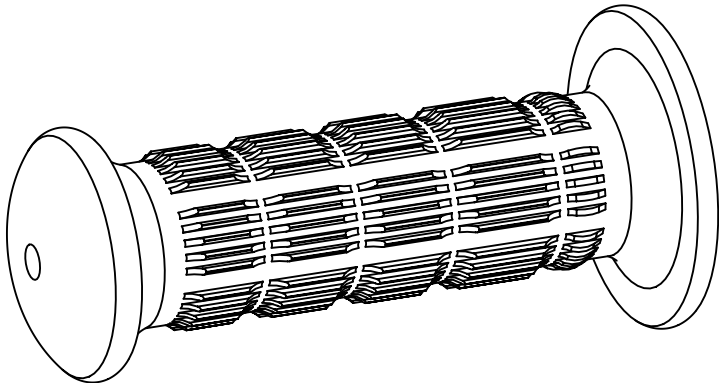

SECTION A-A



- NOTES:
1. DIMENSIONS IN [ ] ARE METRIC.
  2. MATERIAL: FLEXIBLE PVC
  3. COLOR: BLACK
  4. DUROMETER: 65 SHORE A
  5. SURFACE TYPE: GLOSS

	<b>STOCKCAP VISIPAK GRIPWORKS</b> <a href="http://www.stockcap.com">www.stockcap.com</a> <a href="http://www.visipak.com">www.visipak.com</a> <a href="http://www.gripworks.com">www.gripworks.com</a>		
	SINCLAIR & RUSH, INC 123 MANUFACTURERS DR. ARNOLD, MO 63010		
UNLESS OTHERWISE SPECIFIED:  DIMENSIONS ARE IN INCHES	THIS DRAWING CONTAINS CONFIDENTIAL INFORMATION OF SINCLAIR & RUSH INC. AND IS NOT TO BE COPIED, USED OR, DISCLOSED TO OTHERS WITHOUT THE EXPRESS WRITTEN CONSENT OF SINCLAIR & RUSH, INC		
	ALL DIMENSIONS AND SYMBOLS CONFORM TO ANSI Y14.5	DRW <b>JAB</b>	DATE <b>23-JUL-19</b>
		CK <b>BPF</b>	DATE <b>23-JUL-19</b>
		APP <b>BPF</b>	DATE <b>23-JUL-19</b>
<b>SCALE 1:1</b>			
DESCRIPTION <b>INJECTION GRIP-WX-7/8"-0.835-4.450-FPVC-BLACK-65-GLOSS</b>			
SIZE <b>A</b>	SHEET <b>1 OF 1</b>	PART / DRAWING NUMBER <b>041000</b>	REV <b>0</b>

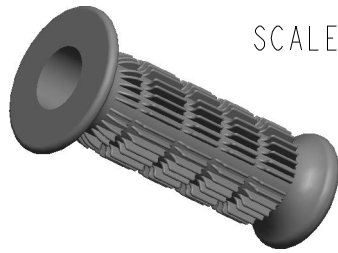

SCALE: 0.375

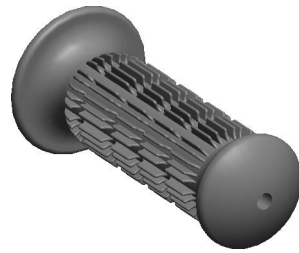

REV	DESCRIPTION	DATE	BY	APP

SECTION A-A

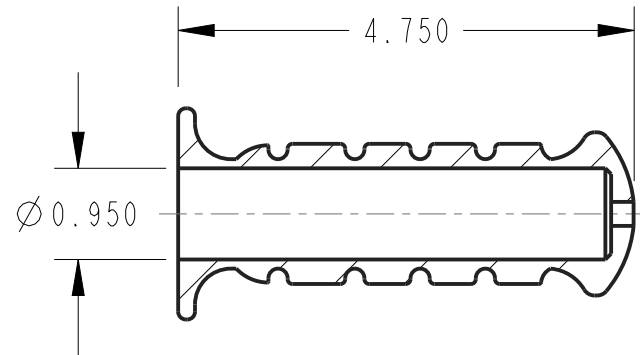
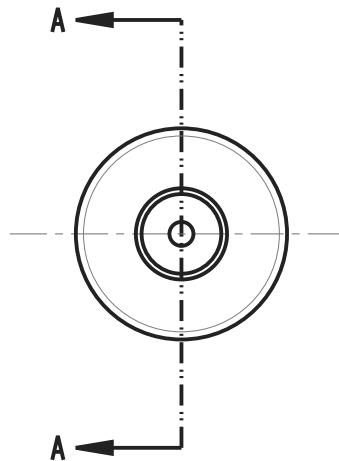

 <b>SINCLAIR &amp; RUSH, INC.</b> 123 MANUFACTURERS DRIVE ARNOLD, MO 63010 <a href="http://www.sinclair-rush.com">www.sinclair-rush.com</a>	<b>STOCKCAP. GRIPWORKS. VISIPAK.</b> <a href="http://www.stockcap.com">www.stockcap.com</a> <a href="http://www.gripworks.com">www.gripworks.com</a> <a href="http://www.visipak.com">www.visipak.com</a>		
	<b>VynaFlex™</b> <a href="http://www.vynaflex.com">www.vynaflex.com</a>	 <a href="http://www.software.com">www.software.com</a>	 <a href="http://www.castlebay.com">www.castlebay.com</a>

THIS DOCUMENT CONTAINS CONFIDENTIAL INFORMATION OF SINCLAIR & RUSH INC. AND IS NOT TO BE COPIED, USED OR, DISCLOSED TO OTHERS WITHOUT THE EXPRESS WRITTEN CONSENT OF SINCLAIR & RUSH INC.

UNLESS OTHERWISE SPECIFIED:  
DIMENSIONS ARE IN INCHES.

ALL DIMENSIONS AND SYMBOLS CONFORM TO ANSI Y14.5	DRW MLA	DATE 23-JUL-15
	CK BMM	DATE 24-JUL-15
	APP BMM	DATE 24-JUL-15
THIRD ANGLE PROJECTION 		SCALE 0.500

- NOTES:
1. DIMENSIONS IN [ ] ARE METRIC.
  2. MATERIAL: FLEXIBLE PVC
  3. COLOR: BLACK
  4. DUROMETER: 65 SHORE A
  5. SURFACE TYPE: GLOSS

DESCRIPTION <b>INJECTION GRIP-WX-1"-0.950-4.750-FPVC-BLACK-65-GLOSS</b>			
SIZE <b>A</b>	SHEET <b>1 OF 1</b>	PART/DRAWING NUMBER <b>190165</b>	REV <b>0</b>