

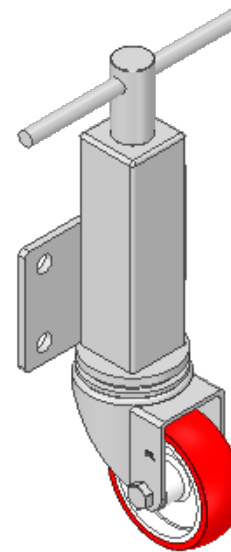

Sinclair & Rush

Global Manufacturer of Plastic, Rubber & Foam Components

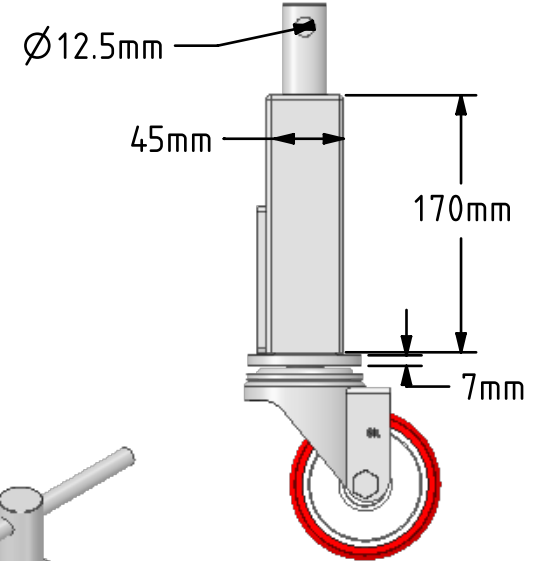
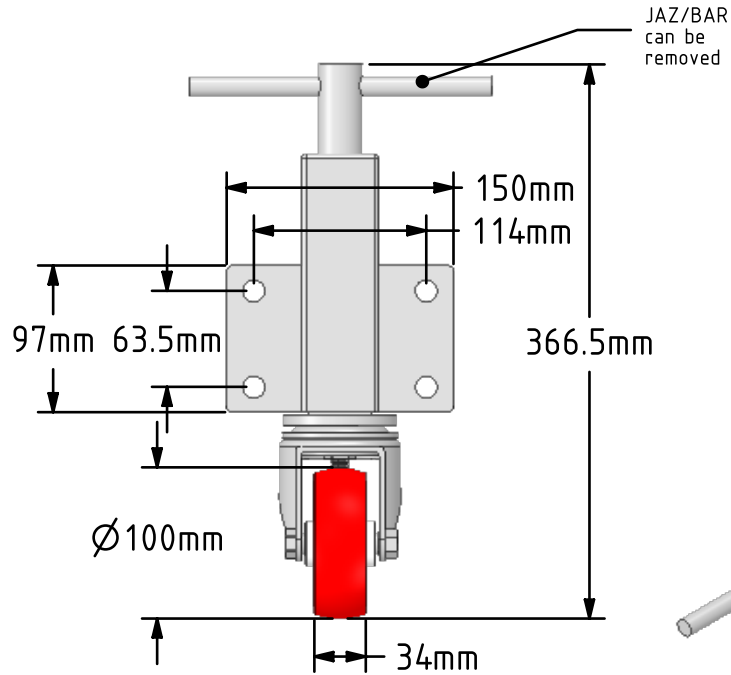
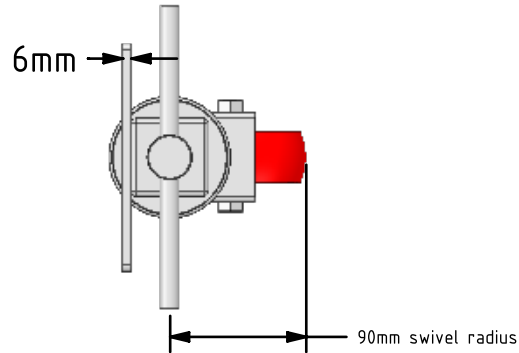

Description:
JKS01

Yellow zinc plated box jacking unit with side fitting plate and a 75mm lift fitted with a 100mm red polyurethane tyre nylon centred plain bore wheel with a load capacity of 200kg Please note Jacking castors are rated on a different principal to other castors and we recommend the total lifted load is divided over just 2 jacking units. 1 extra safety point is when jacked up please beware of any obstacles as a sudden shock could result in the inner square tube bending around the outer tube.



**CALL OUR
SALES TEAM ON
01634 686504**

	NAME	DATE	Sinclair & Rush Ltd.		
DRAWN	Matt	18/02/16	TITLE JKS01		
APPROVED BY	Chris	18/02/16			
SCALE	1:5	18/02/16			
WEIGHT	4kg	18/02/16			
UNLESS OTHERWISE SPECIFIED DIMENSIONS ARE IN MILLIMETRES			SIZE	DWG NO.	REV
Unspecified Tolerances Machining ± 0.25mm Fabrication ± 1mm			A4	JKS01_01	1
			FILE NAME	JKS01_01.PDF	SHEET 1 OF 1



Sinclair & Rush

Global Manufacturer of Plastic, Rubber & Foam Components

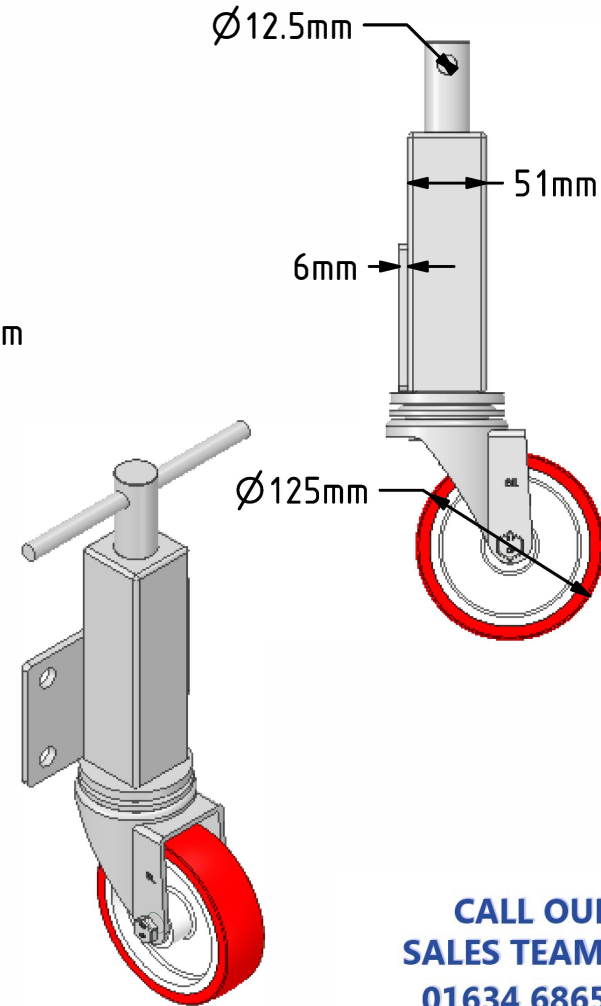
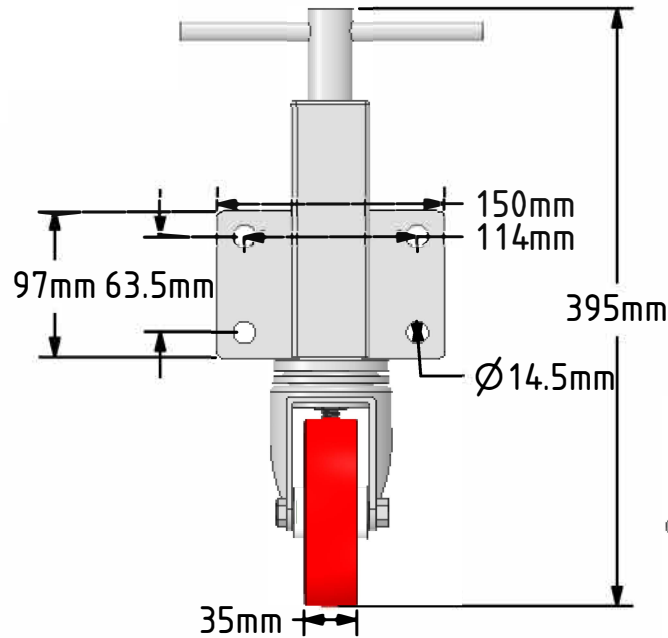
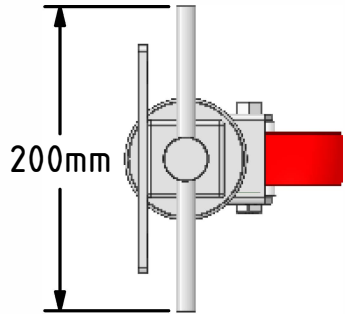

Description:
JKS04

Zinc plated box jacking unit with side fitting plate and a 75mm lift fitted with a 125mm red polyurethane tyred nylon centred roller bearing wheel with a load capacity of 200kg Please note Jacking castors are rated on a different principal to other castors and we recommend the total lifted load is divided over just 2 jacking units. 1 extra safety point is when jacked up please beware of any obstacles as a sudden shock could result in the inner square tube bending around the outer tube.



**CALL OUR
SALES TEAM ON
01634 686504**

	NAME	DATE	Sinclair & Rush Ltd.		
DRAWN	Matt	07/06/18			
APPROVED BY	Tim W	07/06/18	TITLE JKS04		
SCALE	1:5	07/06/18			
WEIGHT	4.416kg	07/06/18	SIZE	DWG NO.	
UNLESS OTHERWISE SPECIFIED DIMENSIONS ARE IN MILLIMETRES			A4	JKS04_01	REV 1
Unspecified Tolerances Machining ± 0.25mm Fabrication ± 1mm			FILE NAME	JKS04_01.PDF	SHEET 1 OF 1



Sinclair & Rush

Global Manufacturer of Plastic, Rubber & Foam Components

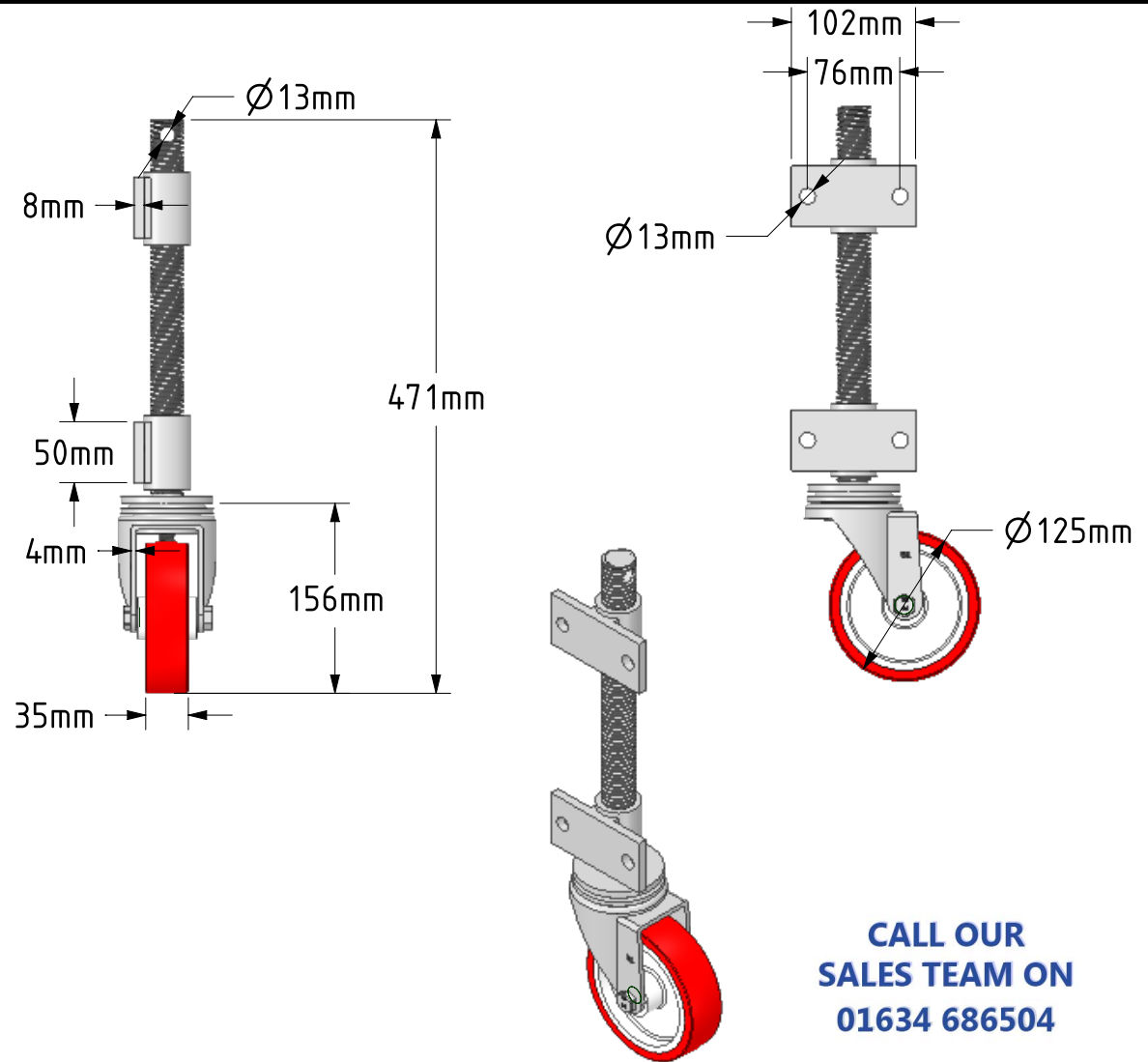
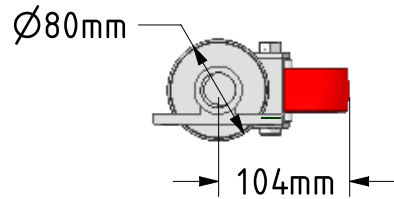

Description:
JKS14

Open screw thread jacking castor with side fitting nuts with 160mm lift fitted with a 125mm white zinc plated swivel pressed steel castor with a red polyurethane tyre white nylon centred roller bearing bore wheel with a load capacity of 200kg Please note Jacking castors are rated on a different principal to other castors and we recommend the total lifted load is divided over just 2 jacking units. 1 extra safety point is when jacked up please beware of any obstacles as a sudden shock could result in bending the thread but more likely the castor will tear away from the screw thread.



**CALL OUR
SALES TEAM ON
01634 686504**

	NAME	DATE	Sinclair & Rush Ltd.		
DRAWN	Matt	29/11/19	TITLE JKS14		
APPROVED BY	Chris	29/11/19			
SCALE	1:6	29/11/19			
WEIGHT	3.62kg	29/11/19			
UNLESS OTHERWISE SPECIFIED DIMENSIONS ARE IN MILLIMETRES			SIZE	DWG NO.	REV
Unspecified Tolerances Machining ± 0.25mm Fabrication ± 1mm			A4	JKS14_01	1
			FILE NAME	JKS14_01.PDF	SHEET 1 OF 1



Sinclair & Rush

Global Manufacturer of Plastic, Rubber & Foam Components

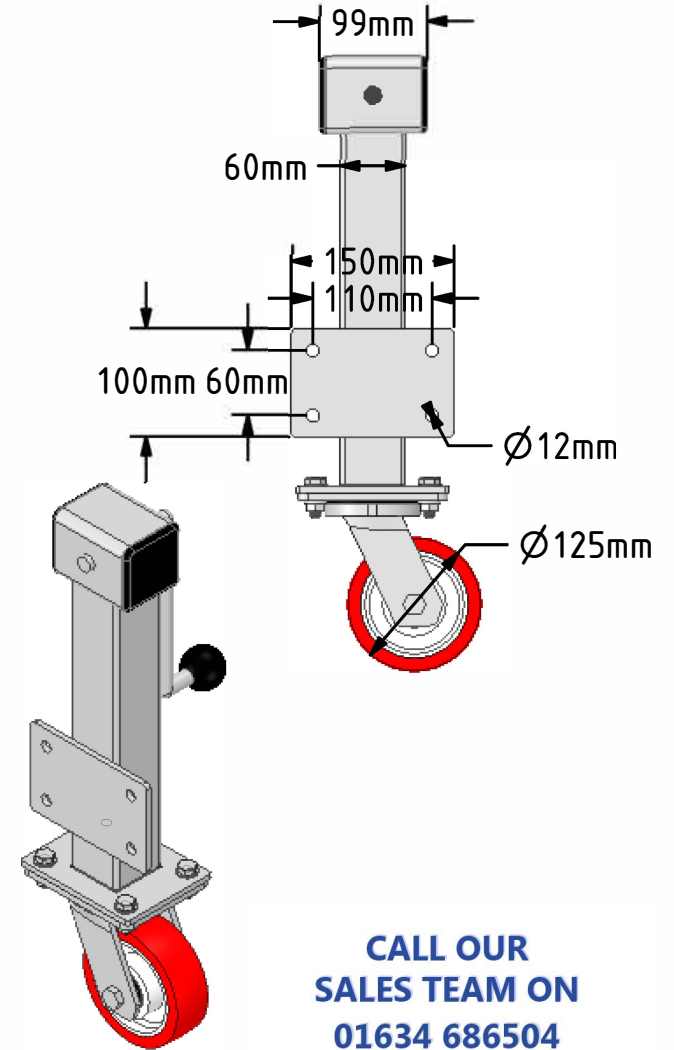
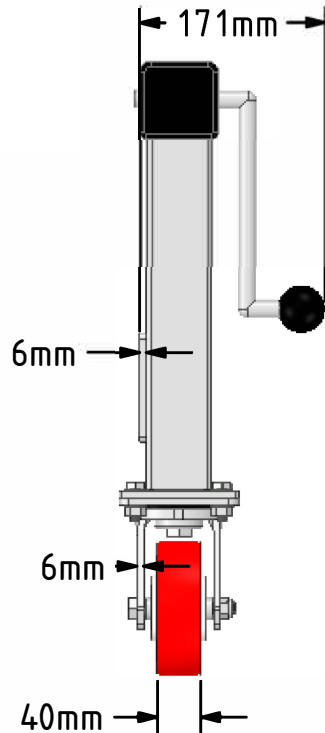
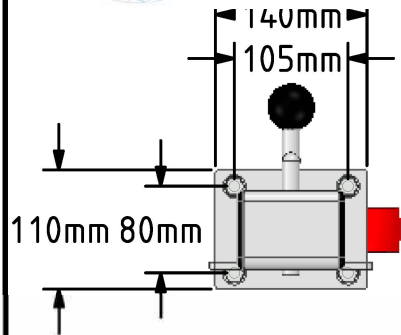

Description:
JKS17

Side winding jacking unit with maximum lift of 200mm fitted with a Fabricated swivel castor with a top plate fixing fitted with a red polyurethane tyre on a white nylon centred wheel with ball bearings. Wheel diameter 125mm, tread width 40mm, maximum Load for the complete unit is capacity 350kg. Please note Jacking castors are rated on a different principal to other castors and we recommend the total lifted load is divided over just 2 jacking units. When jacked up to the height please beware of any obstacles as a sudden shock could result in the inner square tube bending around the outer tube. DO NOT OVERWIND Handle excessively more than what is needed as this will cause the pin in the gearbox to shear. (This is a safety precaution against over loading the unit)



**CALL OUR
SALES TEAM ON
01634 686504**

	NAME	DATE	Sinclair & Rush Ltd.		
DRAWN	Matt	20/07/18			
APPROVED BY	Chris	20/07/18			
SCALE	1:7	20/07/18			
WEIGHT	10.033kg	20/07/18	TITLE JKS17		
UNLESS OTHERWISE SPECIFIED DIMENSIONS ARE IN MILLIMETRES			SIZE	DWG NO.	REV
Unspecified Tolerances Machining ± 0.25mm Fabrication ± 1mm			A4	JKS17_01	1
			FILE NAME	JKS17_01.PDF	SHEET 1 OF 1



Sinclair & Rush

Global Manufacturer of Plastic, Rubber & Foam Components

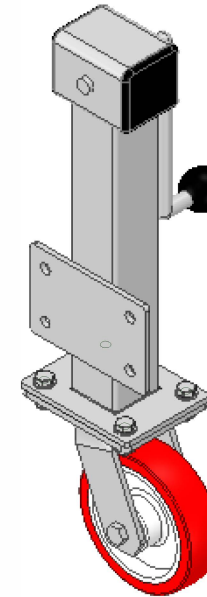
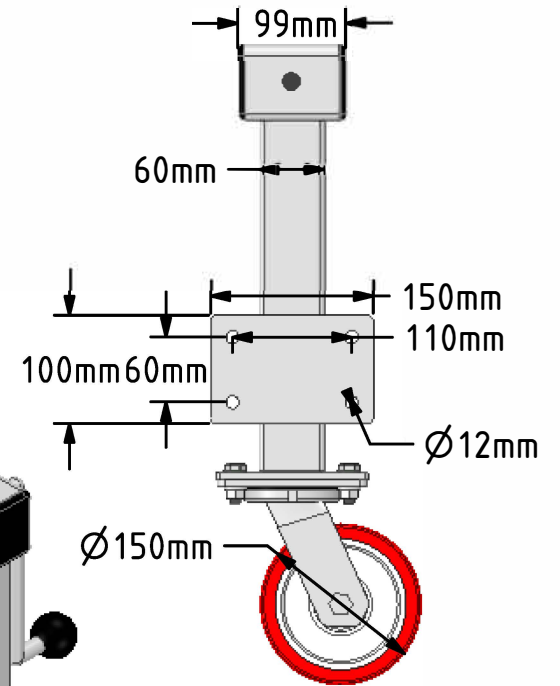
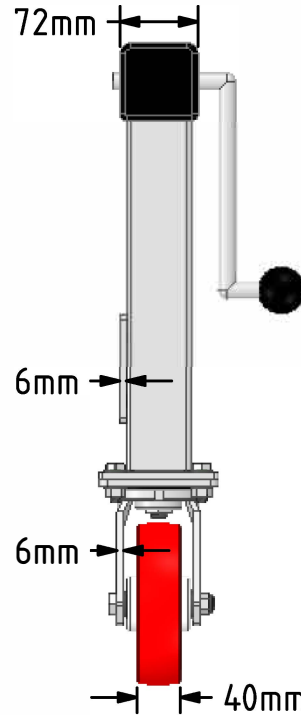
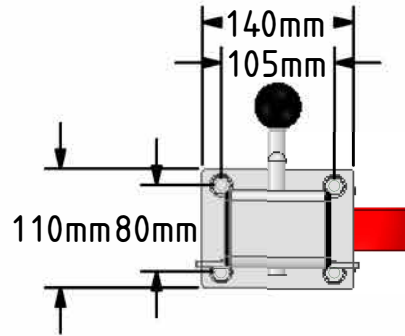

Description:
JKS18

Side winding jacking unit with maximum lift of 200mm fitted with a Fabricated swivel castor with a top plate fixing fitted with a red polyurethane tyre on a white nylon centred wheel. Wheel diameter 150mm, tread width 40mm, maximum Load for the complete unit is capacity 500kg. Please note Jacking castors are rated on a different principal to other castors and we recommend the total lifted load is divided over just 2 jacking units. When jacked up to the height please be aware of any obstacles as a sudden shock could result in the inner square tube bending around the outer tube.

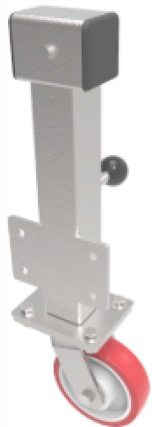

**CALL OUR
SALES TEAM ON
01634 686504**

	NAME	DATE	Sinclair & Rush Ltd.		
DRAWN	Matt	08/06/18	TITLE JKS18		
APPROVED BY	Chris	08/06/18			
SCALE	1:7	08/06/18			
WEIGHT	10.175kg	08/06/18			
UNLESS OTHERWISE SPECIFIED DIMENSIONS ARE IN MILLIMETRES			SIZE	DWG NO.	REV
Unspecified Tolerances Machining ± 0.25mm Fabrication ± 1mm			A4	JKS18_01	1
			FILE NAME	JKS18_01.PDF	SHEET 1 OF 1



Sinclair & Rush

Global Manufacturer of Plastic, Rubber & Foam Components

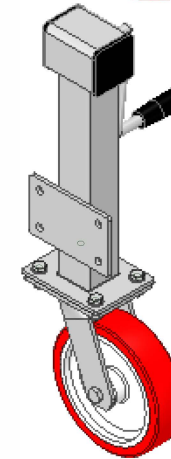
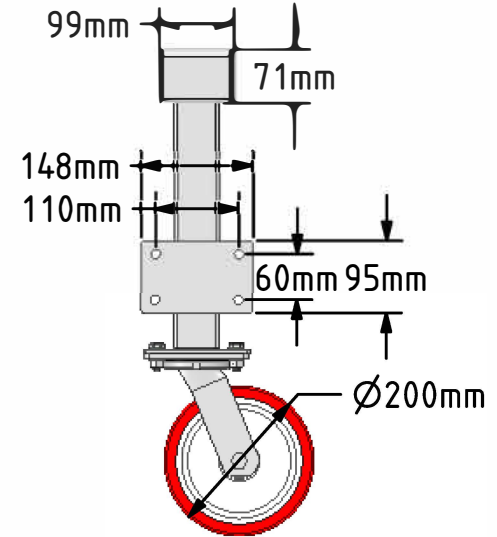
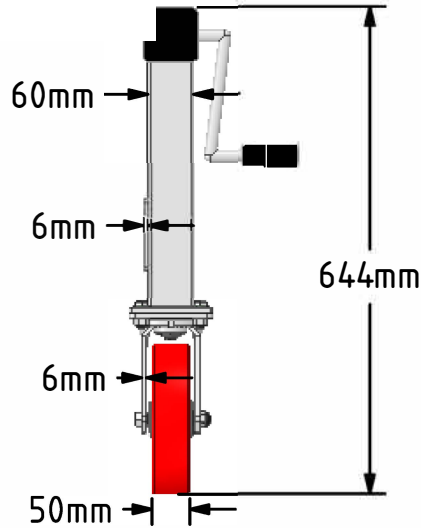
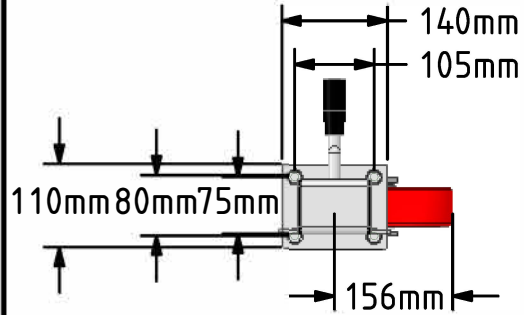

Description:
JKS22

Side winding jacking unit with maximum lift of 200mm fitted with a Fabricated swivel castor with a top plate fixing fitted with a red polyurethane tyre on a white nylon centred wheel with roller bore. Wheel diameter 200mm, tread width 50mm, maximum Load for the complete unit is capacity 500kg. Please note Jacking castors are rated on a different principal to other castors and we recommend the total lifted load is divided over just 2 jacking units. When jacked up to the height please beware of any obstacles as a sudden shock could result in the inner square tube bending around the outer tube.



**CALL OUR
SALES TEAM ON
01634 686504**

	NAME	DATE	Sinclair & Rush Ltd.		
DRAWN	Matt	12/05/17			
APPROVED BY	Chris	12/05/17			
SCALE	1:10	12/05/17			
WEIGHT	10.939kg	12/05/17	TITLE JKS22		
UNLESS OTHERWISE SPECIFIED DIMENSIONS ARE IN MILLIMETRES			SIZE A4	DWG NO. JKS22_01	REV 1
Unspecified Tolerances Machining ± 0.25mm Fabrication ± 1mm			FILE NAME JKS22_01.PDF	SHEET 1 OF 1	



Sinclair & Rush

Global Manufacturer of Plastic, Rubber & Foam Components

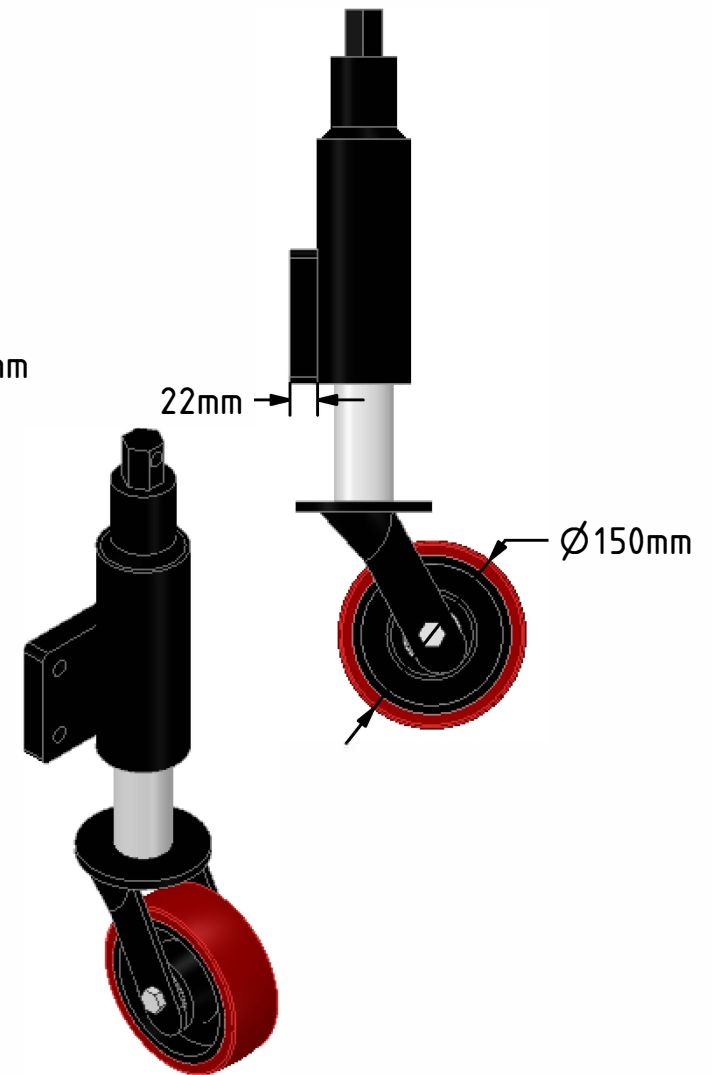
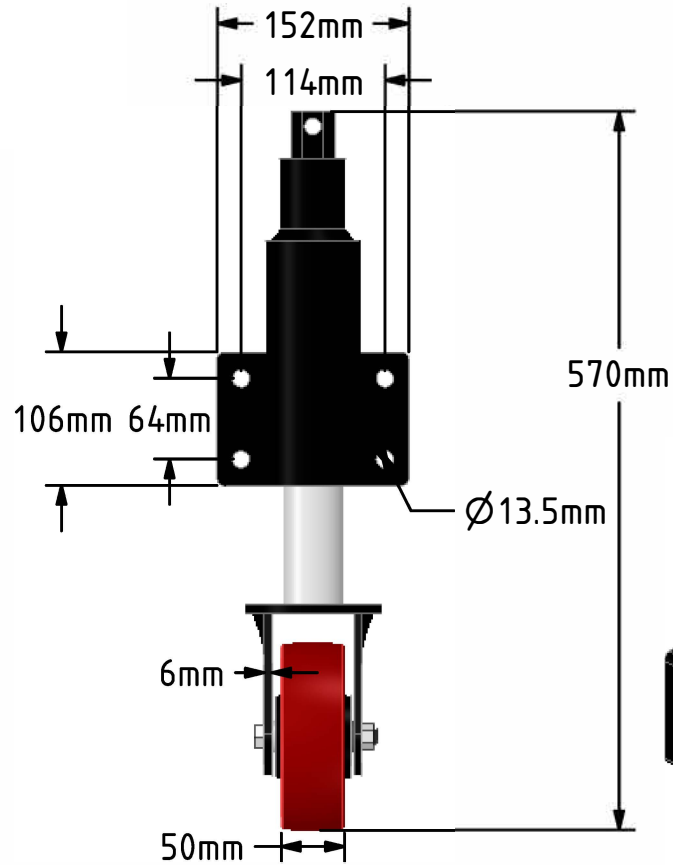
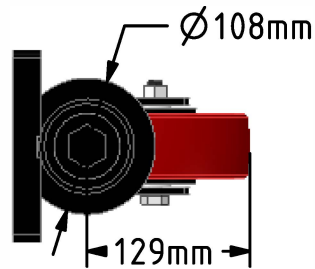

Description:
JKS25

Fabricated 75mm lift swivel jacking bracket with fixing plate fitted with a brown polyurethane tyre cast iron centred wheel with ball bearings. Wheel diameter 150mm, tread width 50mm, overall height 570mm, plate size 152mm x 106mm, hole centres 114mm x 64mm Load capacity 750kg.

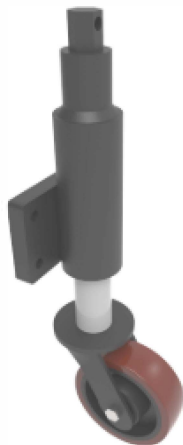

**CALL OUR
SALES TEAM ON
01634 686504**

	NAME	DATE	Sinclair & Rush Ltd.		
DRAWN	Matt	08/04/19	TITLE JKS25		
APPROVED BY	Chris	08/04/19			
SCALE	1:6	08/04/19			
WEIGHT	15.199kg	08/04/19			
UNLESS OTHERWISE SPECIFIED DIMENSIONS ARE IN MILLIMETRES			SIZE	DWG NO.	REV
Unspecified Tolerances Machining ± 0.25mm Fabrication ± 1mm			A4	JKS25_02	2
			FILE NAME	JKS25_02.PDF	SHEET 1 OF 1



Sinclair & Rush

Global Manufacturer of Plastic, Rubber & Foam Components

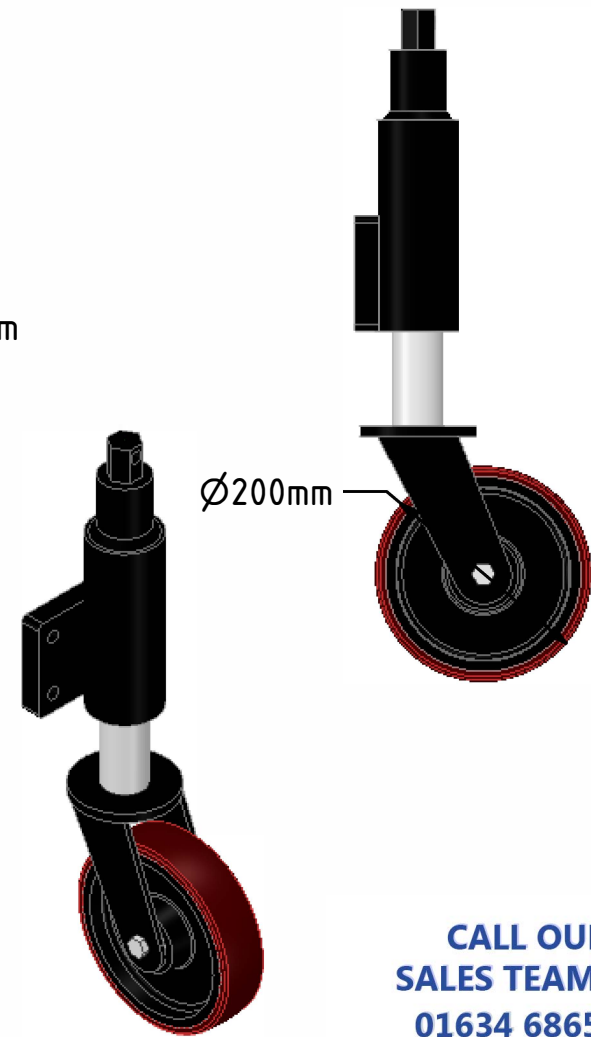
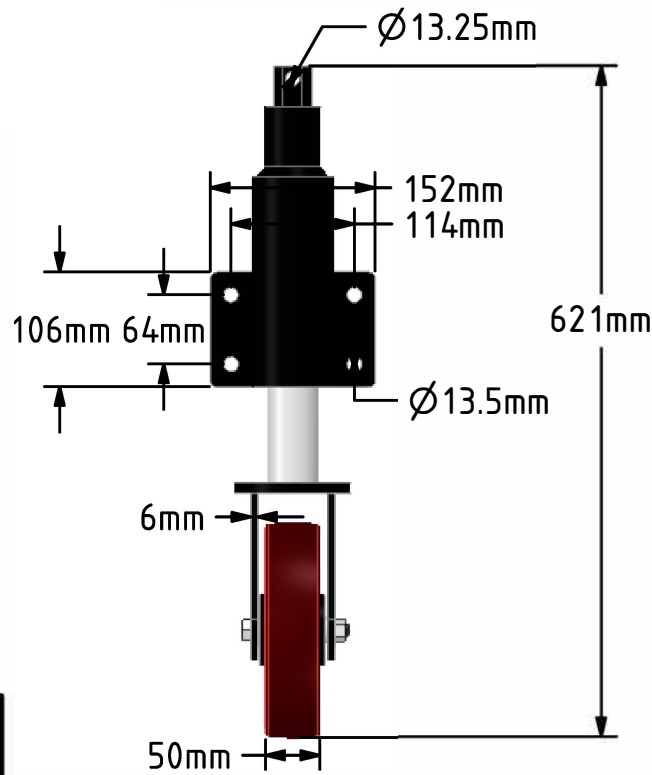
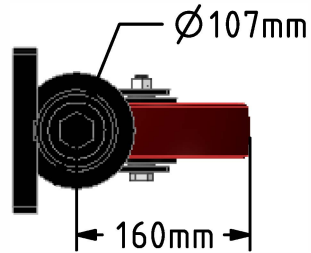

Description:
JKS27

Fabricated 75mm lift swivel jacking bracket with fixing plate fitted with a brown polyurethane tyred cast iron centred wheel with ball bearings. Wheel diameter 200mm, tread width 50mm, overall height 621mm, plate size 152mm x 106mm, hole centres 114mm x 64mm Load capacity 1000kg.

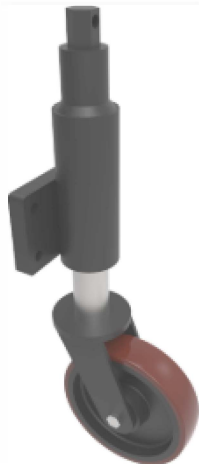

**CALL OUR
SALES TEAM ON
01634 686504**

	NAME	DATE	Sinclair & Rush Ltd.		
DRAWN	Matt	12/06/18	TITLE JKS27		
APPROVED BY	Tim W	12/06/18			
SCALE	1:7	12/06/18			
WEIGHT	16.73kg	12/06/18			
UNLESS OTHERWISE SPECIFIED DIMENSIONS ARE IN MILLIMETRES			SIZE A4	DWG NO. JKS27_01	REV 1
Unspecified Tolerances Machining ± 0.25mm Fabrication ± 1mm			FILE NAME JKS27_01.PDF	SHEET 1 OF 1	

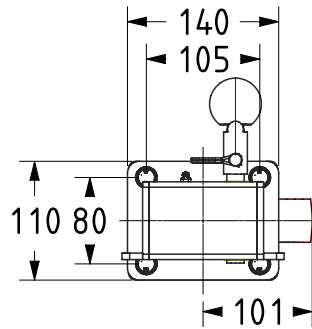
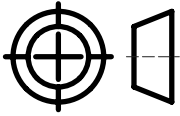

Sinclair & Rush
Global Manufacturer of Plastic, Rubber & Foam Components

Bearing Type Ball
Tread (mm) 40
Castor Swivel Radius (mm) 101
Wheel Material Polyurethane on Nylon
Wheel Dia (mm) 125
Castor Option Swivel
Load Capacity (kg) 350
Castor Fixing Plate
Shore Hardness 92 Shore A
Handle Type Removable

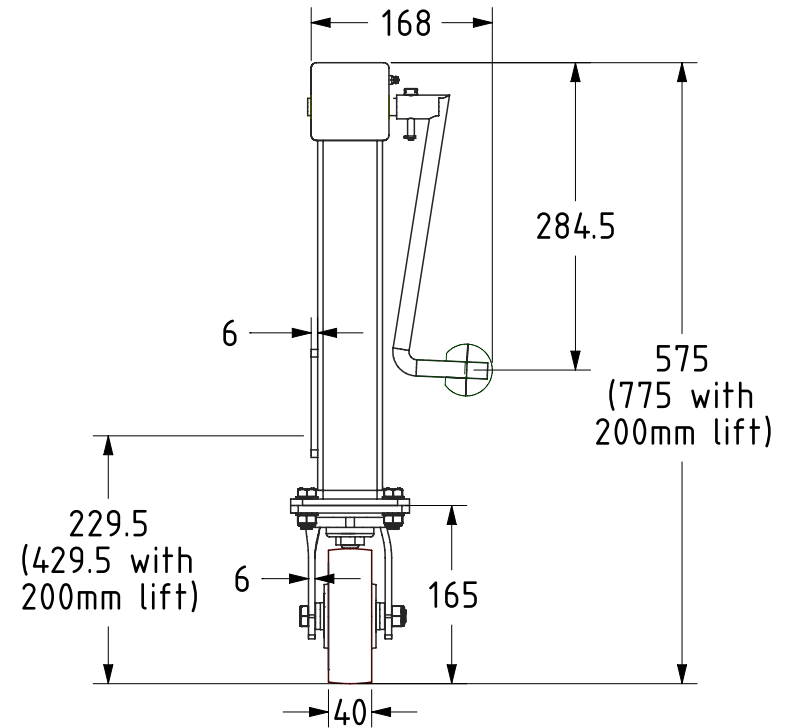
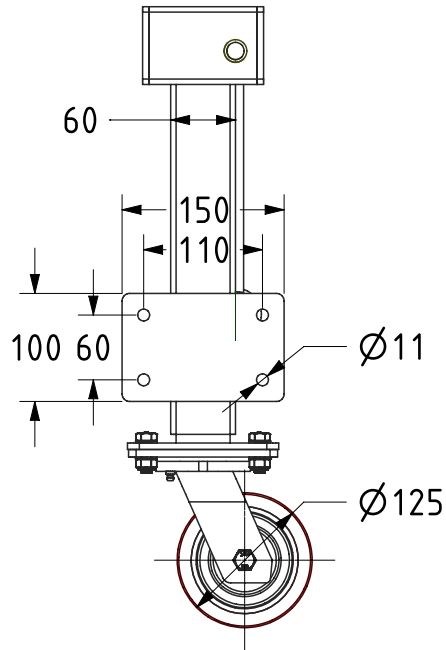

UNLESS OTHERWISE SPECIFIED DIMENSIONS ARE IN MILLIMETRES
Unspecified Tolerances
Machining ± 0.25mm
Fabrication ± 1mm

Sinclair & Rush Ltd
11-13 Spectrum West,
St Laurence Avenue,
Maidstone ME16 0LL
01634 686 504

	NAME	DATE
DRAWN	Matt	18/11/22
APPROVED BY	Kevin	18/11/22
SCALE	1:7	
WEIGHT	9.956kg	



Sinclair & Rush
Global Manufacturer of Plastic, Rubber & Foam Components

DWG NO.	JKS17RH	REV	1
JKS17RH		SHEET 1 OF 1	

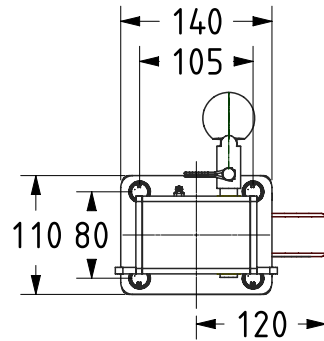
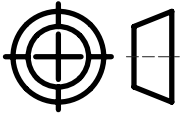

Sinclair & Rush
Global Manufacturer of Plastic, Rubber & Foam Components

Bearing Type Roller
Tread (mm) 50
Castor Swivel Radius (mm) 125
Wheel Material Polyurethane on Nylon
Wheel Dia (mm) 150
Castor Option Swivel
Load Capacity (kg) 500
Castor Fixing Plate
Shore Hardness 92 Shore A
Handle Type Removable

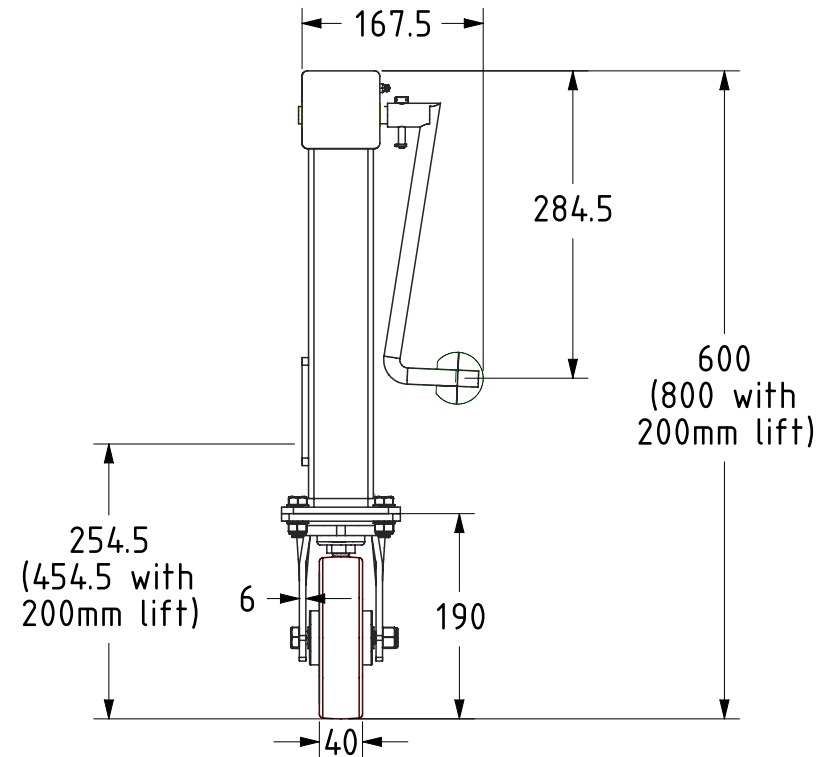
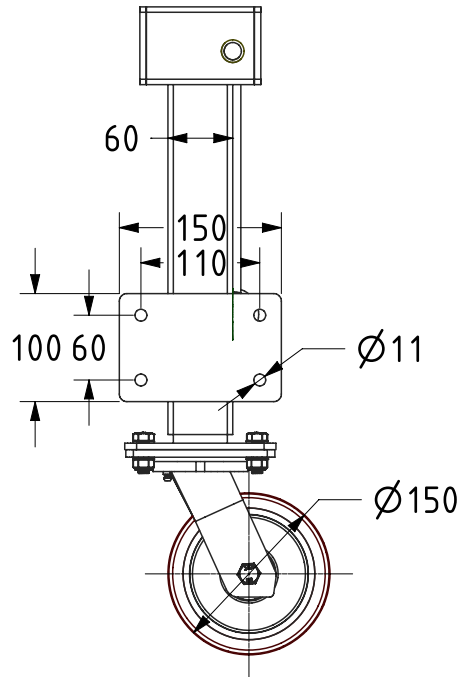

UNLESS OTHERWISE SPECIFIED DIMENSIONS ARE IN MILLIMETRES
Unspecified Tolerances
Machining ± 0.25mm
Fabrication ± 1mm

Sinclair & Rush Ltd
11-13 Spectrum West,
St Laurence Avenue,
Maidstone ME16 0LL
01634 686 504

	NAME	DATE
DRAWN	Matt	18/11/22
APPROVED BY	Kevin	18/11/22
SCALE	1:7	
WEIGHT	9.993kg	



Sinclair & Rush
Global Manufacturer of Plastic, Rubber & Foam Components

DWG NO.	JKS18RH	REV	1
	JKS18RH	SHEET 1 OF 1	

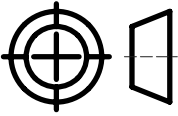

Sinclair & Rush
Global Manufacturer of Plastic, Rubber & Foam Components

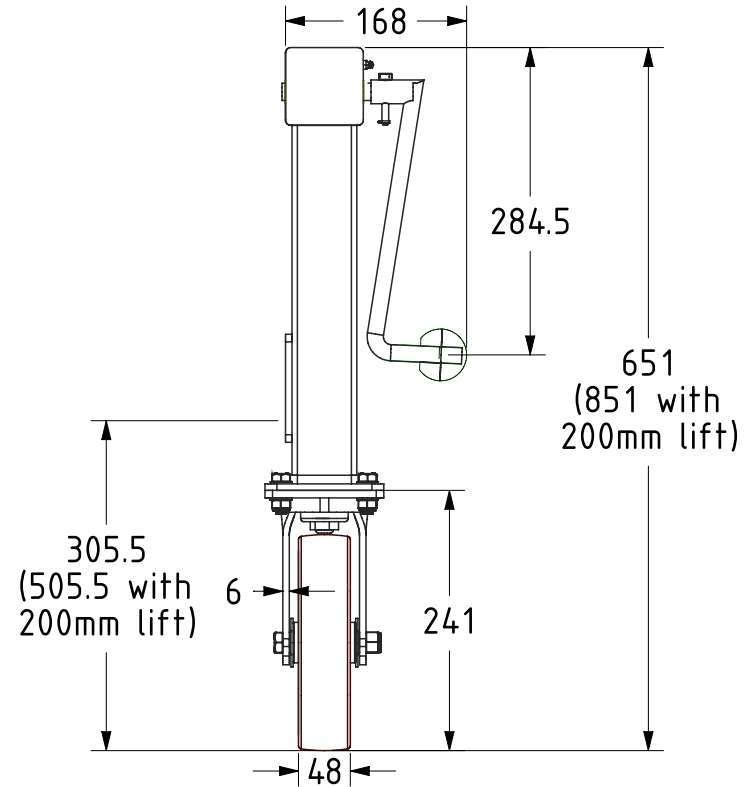
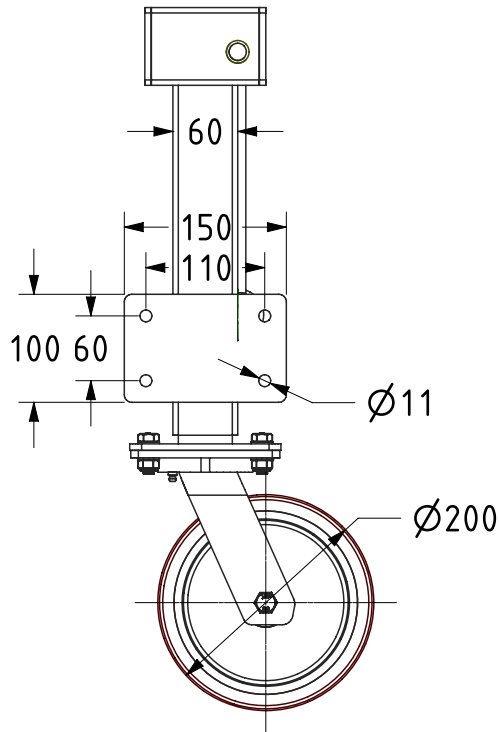
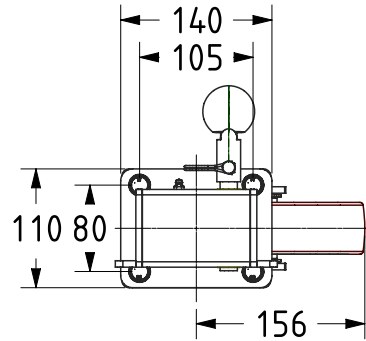

Tread (mm) 48
Castor Swivel Radius (mm) 156
Bearing Type Plain
Wheel Material Polyurethane on Nylon
Wheel Dia (mm) 200
Load Capacity (kg) 600
Castor Fixing Plate
Castor Option Swivel
Shore Hardness 92 Shore A
Handle Type Removable

UNLESS OTHERWISE SPECIFIED DIMENSIONS ARE IN MILLIMETRES
Unspecified Tolerances
Machining ± 0.25mm
Fabrication ± 1mm

Sinclair & Rush Ltd
11-13 Spectrum West,
St Laurence Avenue,
Maidstone ME16 0LL
01634 686 504

	NAME	DATE
DRAWN	Matt	18/11/22
APPROVED BY	Kevin	18/11/22
SCALE	1:7	
WEIGHT	10.493kg	



Sinclair & Rush
Global Manufacturer of Plastic, Rubber & Foam Components

DWG NO.	JKS22RH	REV	1
JKS22RH		SHEET 1 OF 1	

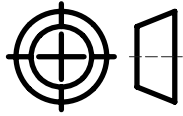

Sinclair & Rush
Global Manufacturer of Plastic, Rubber & Foam Components

Bearing Type - Ball
Tread (mm) - 50
Castor Swivel Radius (mm) - 156
Wheel Material - Polyurethane on Nylon
Wheel Dia (mm) - 200
Castor Option - Swivel
Load Capacity (kg) - 600
Castor Fixing - Plate
Shore Hardness - 92 Shore A
Handle Type - Removable

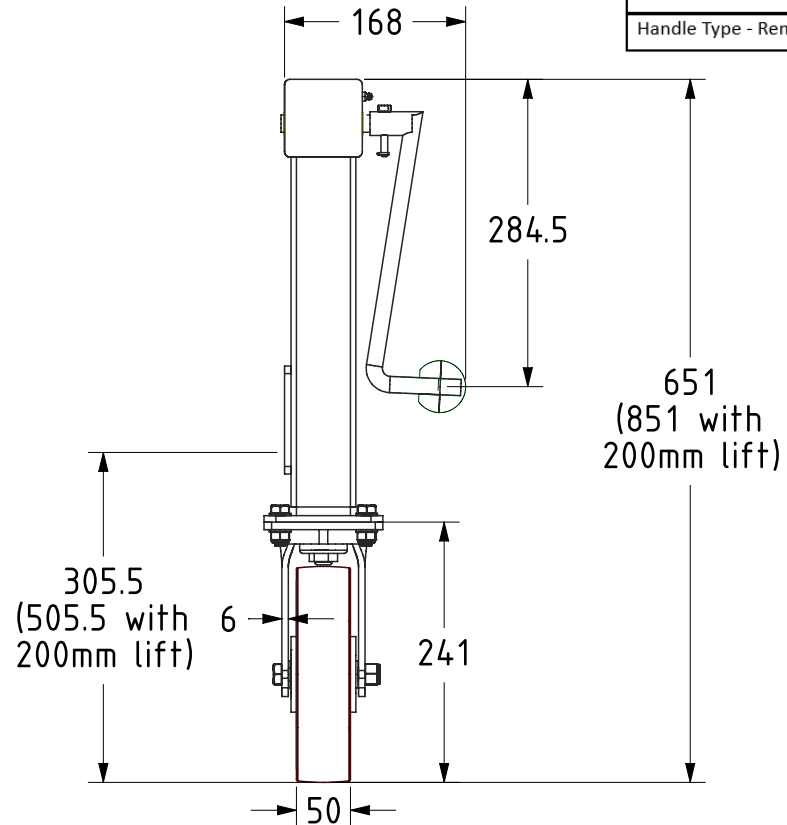
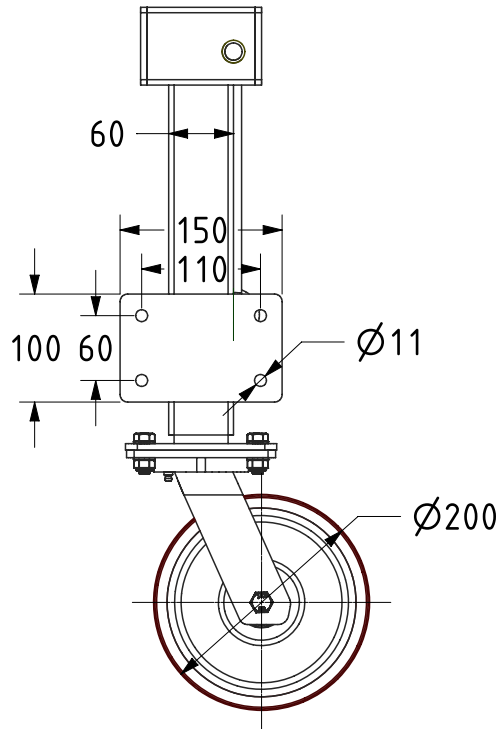
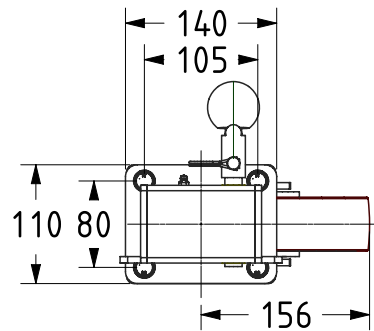

UNLESS OTHERWISE SPECIFIED DIMENSIONS ARE IN MILLIMETRES
Unspecified Tolerances
Machining ± 0.25mm
Fabrication ± 1mm

Sinclair & Rush Ltd
11-13 Spectrum West,
St Laurence Avenue,
Maidstone ME16 0LL
01634 686 504

	NAME	DATE
DRAWN	Matt	18/11/22
APPROVED BY	Kevin	18/11/22
SCALE	1:7	
WEIGHT	10.633kg	



DWG NO.	JKS23RH	REV	1
JKS23RH		SHEET 1 OF 1	