

Sinclair & Rush | 01634 686504 |
sales@sinclair-rush.co.uk

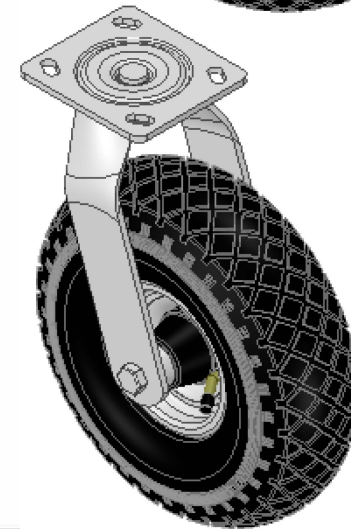

Description:
CPNW3

Fabricated swivel castor with a top plate fixing fitted with a 6-ply black diamond pattern pneumatic tyre with a grey steel centre and roller bearing. Wheel diameter 260, tread width 85mm, overall height 318mm, plate size 115mm x 105mm, hole centres 92mm x 67 or 76mm x 76mm. Load capacity 270kg at max speed 4KPH, for non-towing applications please note we manufacture to order and therefore a 24 hour delivery may not be possible.

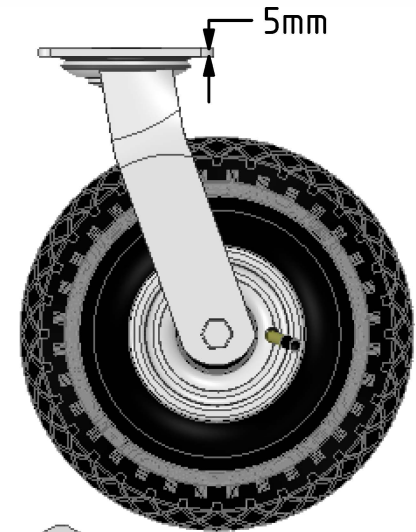
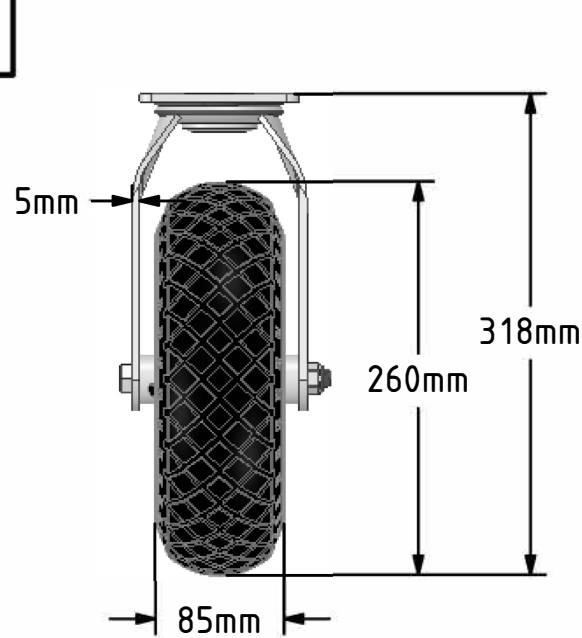
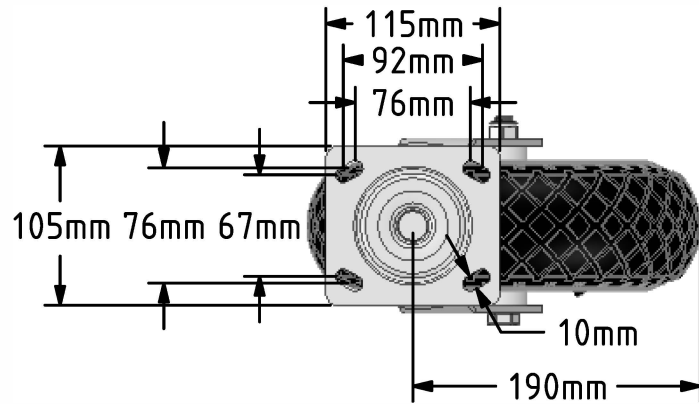

	NAME	DATE
DRAWN	Matt	09/05/19
APPROVED BY	Chris	09/05/19
SCALE	1:5	09/05/19
WEIGHT	3.305kg	09/05/19

UNLESS OTHERWISE SPECIFIED DIMENSIONS ARE IN MILLIMETRES
Unspecified Tolerances
Machining ± 0.25mm
Fabrication ± 1mm

Sinclair & Rush Ltd.

TITLE		CPNW3
SIZE	DWG NO.	REV
A4	CPNW3_02	2
FILE NAME	CPNW3_02.PDF	SHEET 1 OF 1

Sinclair & Rush | 01634 686504 |
sales@sinclair-rush.co.uk

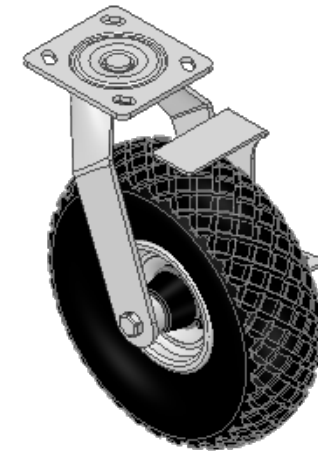
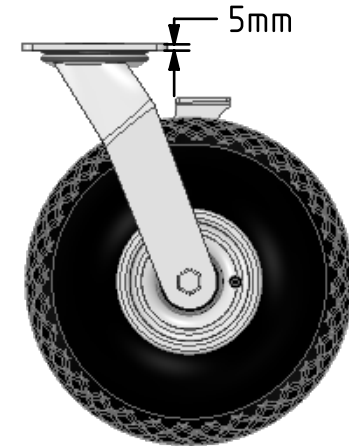
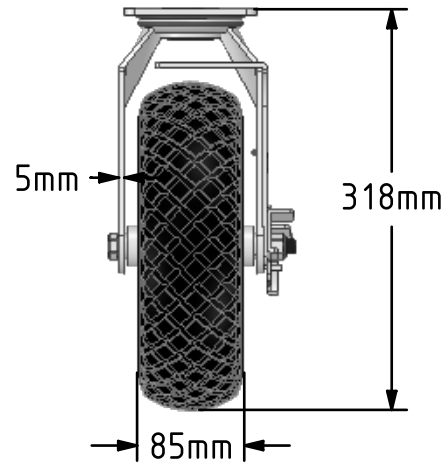
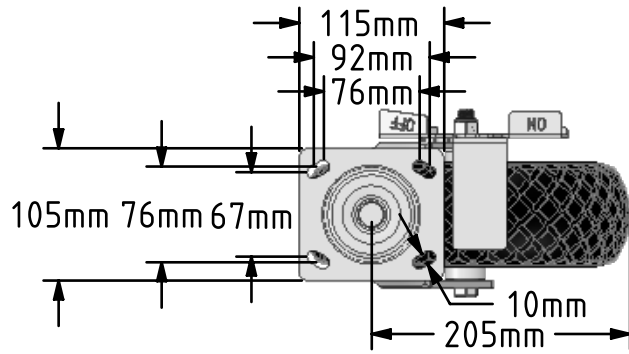

Description:
CPNW4

Fabricated swivel castor with a top plate fixing fitted with a 6 ply black diamond pattern pneumatic tyre with a grey steel centre with roller bearing and side fitting wheel brake. Wheel diameter 260, tread width 85mm, overall height 318mm, plate size 115mm x 105mm, hole centres 92mm x 67 or 76mm x 76mm. Load capacity 270kg.at max speed 4KPH, for non-towing applications please note we manufacture to order and therefore a 24 hour delivery may not be possible..



	NAME	DATE
DRAWN	Matt	07/11/17
APPROVED BY	Tim W	07/11/17
SCALE	1:6	07/11/17
WEIGHT	4.232kg	07/11/17

UNLESS OTHERWISE SPECIFIED DIMENSIONS ARE IN MILLIMETRES
Unspecified Tolerances
Machining ± 0.25mm
Fabrication ± 1mm

Sinclair & Rush Ltd.

TITLE		REV
CPNW4		1
SIZE	DWG NO.	
A4	CPNW4_01	
FILE NAME	CPNW4_01.PDF	SHEET 1 OF 1

Sinclair & Rush | 01634 686504 |
sales@sinclair-rush.co.uk

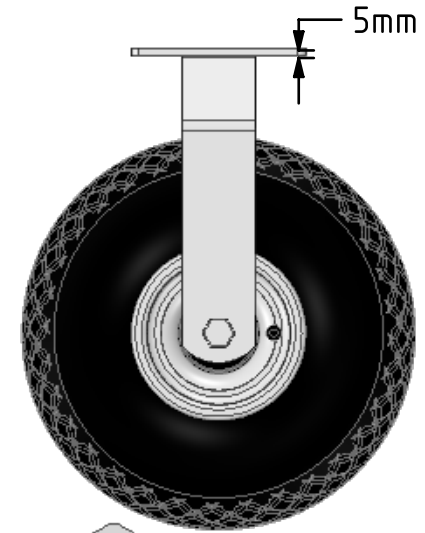
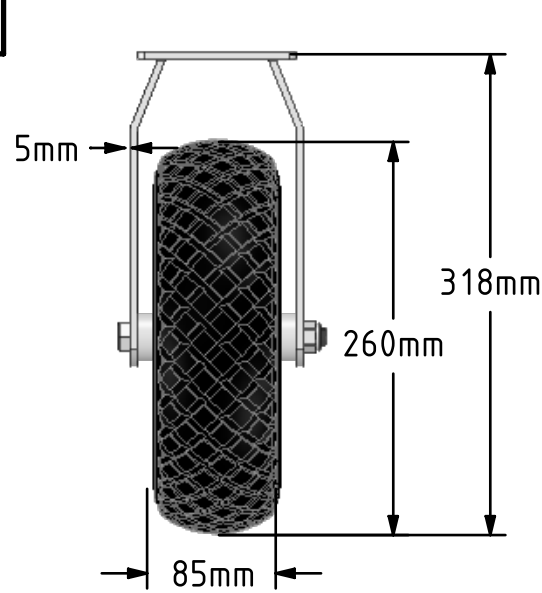
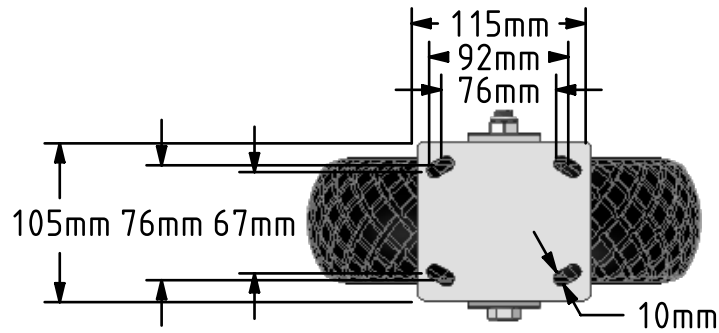

Description:
CPNWS

Fabricated fixed castor with a top plate fixing fitted with a 6 ply black diamond pattern pneumatic tyre with a grey steel centre and roller bearing. Wheel diameter 260, tread width 85mm, overall height 318mm, plate size 115mm x 105mm, hole centres 92mm x 67 or 76mm x 76mm. Load capacity 270kg at max speed 4KPH, for non-towing applications



	NAME	DATE
DRAWN	Matt	09/01/19
APPROVED BY	Tim W	09/01/19
SCALE	1:5	09/01/19
WEIGHT	3.08kg	09/01/19

UNLESS OTHERWISE SPECIFIED DIMENSIONS ARE IN MILLIMETRES

Unspecified Tolerances
Machining ± 0.25mm
Fabrication ± 1mm

Sinclair & Rush Ltd.

TITLE

CPNWS

SIZE DWG NO.

A4

CPNWS_01

REV

1

FILE NAME

CPNWS_01.PDF

SHEET 1 OF 1

Sinclair & Rush | 01634 686504
 | sales@sinclair-rush.co.uk

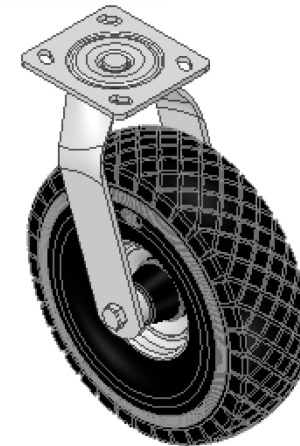
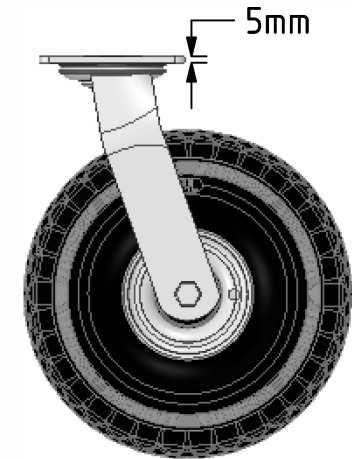
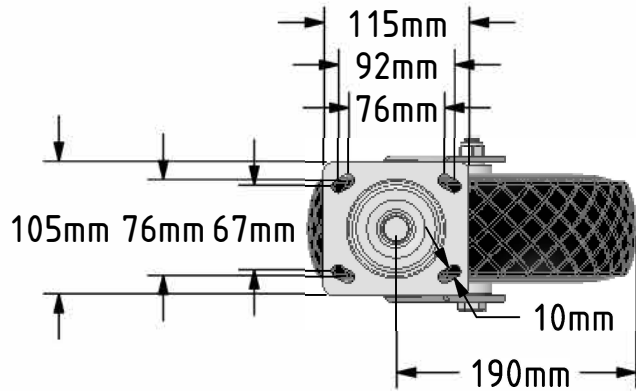

Description:
 CPNW9

Fabricated swivel castor with a top plate fixing fitted with a black diamond pattern puncture proof tyre grey steel disc centred wheel with roller bearing. Wheel diameter 260mm, tread width 85mm, overall height 318mm, plate size 115mm x 105mm, hole centres 92mm x 67mm or 76mm x 76mm. Load capacity 150kg



	NAME	DATE
DRAWN	Matt	07/08/19
APPROVED BY	Kevin	07/08/19
SCALE	1:6	07/08/19
WEIGHT	4.013kg	07/08/19

Sinclair & Rush Ltd.

TITLE

CPNW9

UNLESS OTHERWISE SPECIFIED DIMENSIONS ARE IN MILLIMETRES

Unspecified Tolerances
 Machining ± 0.25mm
 Fabrication ± 1mm

SIZE DWG NO.
 A4

CPNW9_01

REV
 1

FILE NAME

CPNW9_01.PDF

SHEET 1 OF 1

Sinclair & Rush | 01634 686504 |
sales@sinclair-rush.co.uk

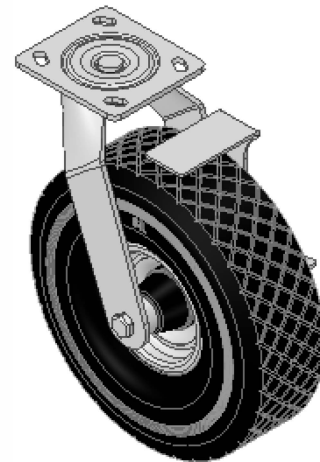
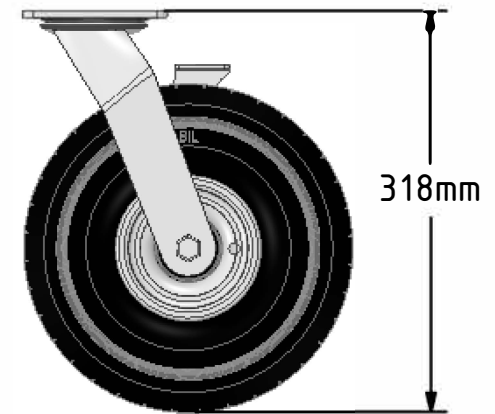
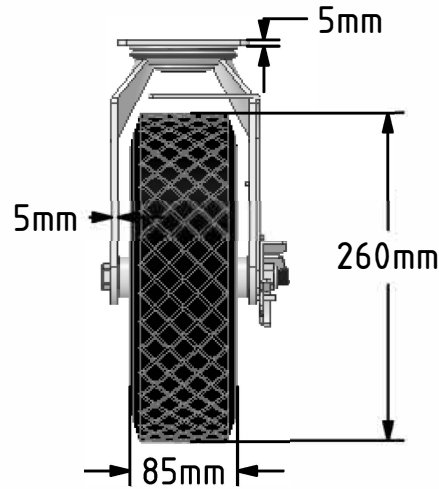
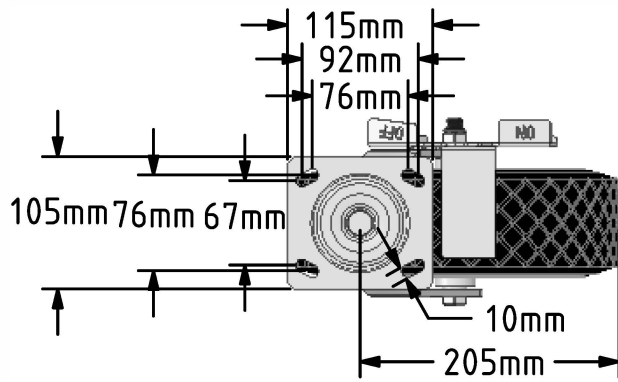

Description:
CPNW10

Fabricated swivel castor with a top plate fixing fitted with a black diamond pattern puncture proof tyre grey steel disc centred wheel with roller bearing and side fitting wheel brake. Wheel diameter 260, tread width 85mm, overall height 318mm, plate size 115mm x 105mm, hole centres 92mm x 67mm or 76mm x 76mm. Load capacity 150kg



	NAME	DATE
DRAWN	Matt	04/08/17
APPROVED BY	Chris	04/08/17
SCALE	1:6	04/08/17
WEIGHT	4.815kg	04/08/17

UNLESS OTHERWISE SPECIFIED DIMENSIONS ARE IN MILLIMETRES

Unspecified Tolerances
Machining ± 0.25mm
Fabrication ± 1mm

Sinclair & Rush Ltd.

TITLE

CPNW10

SIZE DWG NO.

A4

CPNW10_01

REV
1

FILE NAME

CPNW10_01.PDF

SHEET 1 OF 1

Sinclair & Rush | 01634 686504 |
sales@sinclair-rush.co.uk

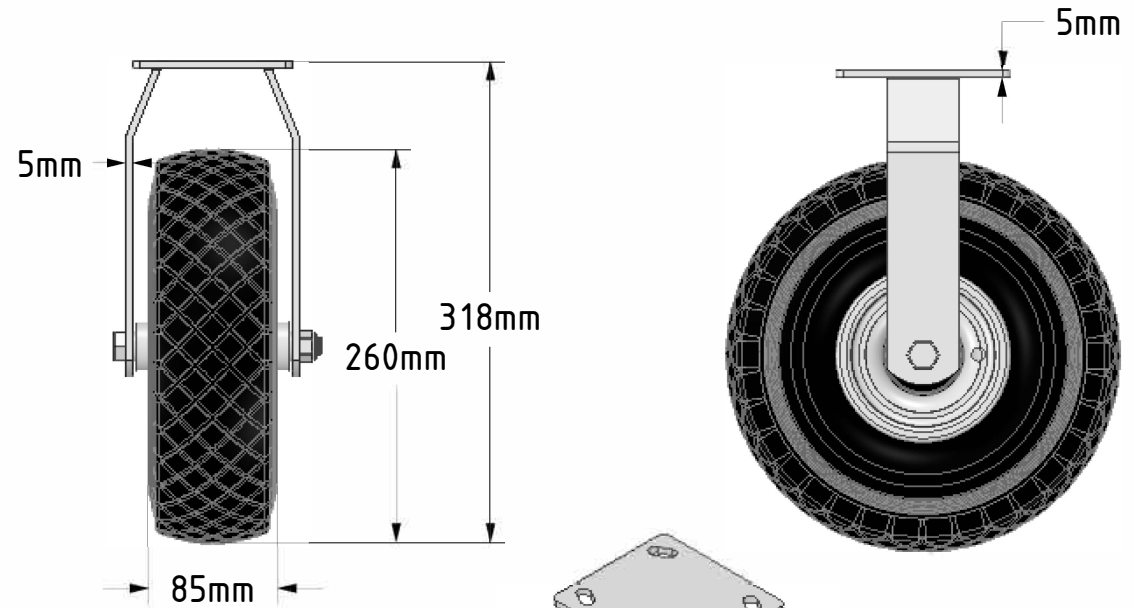
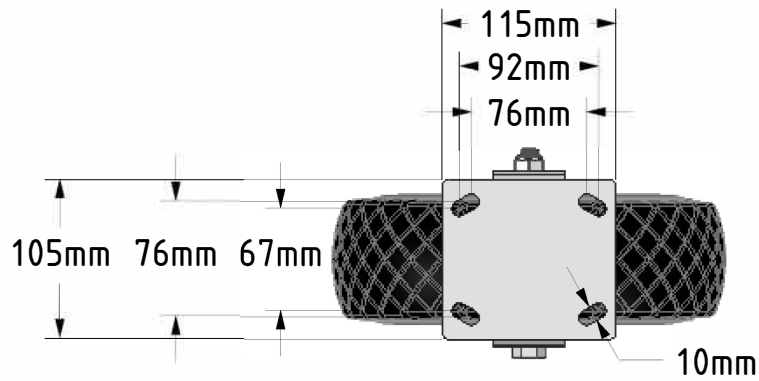

Description:
CPNW11

Fabricated fixed castor with a top plate fixing fitted with a black diamond pattern puncture proof tyre grey steel disc centred wheel with roller bearing. Wheel diameter 260, tread width 85mm, overall height 318mm, plate size 115mm x 105mm, hole centres 92mm x 67mm or 76mm x 76mm. Load capacity 150kg



	NAME	DATE
DRAWN	Matt	29/11/19
APPROVED BY	Chris	29/11/19
SCALE	1:5	29/11/19
WEIGHT	3.663kg	29/11/19

Sinclair & Rush Ltd.

TITLE
CPNW11

UNLESS OTHERWISE SPECIFIED DIMENSIONS ARE IN MILLIMETRES
Unspecified Tolerances
Machining ± 0.25mm
Fabrication ± 1mm

SIZE	DWG NO.	REV
A4	CPNW11_01	1
FILE NAME	CPNW11_01.PDF	SHEET 1 OF 1

Sinclair & Rush | 01634 686504 |
sales@sinclair-rush.co.uk

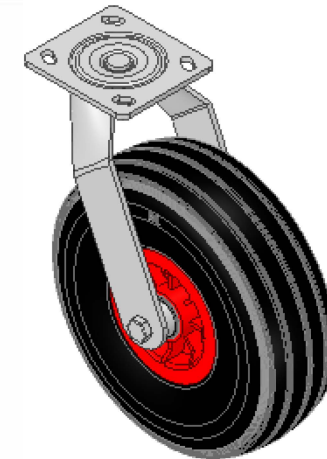
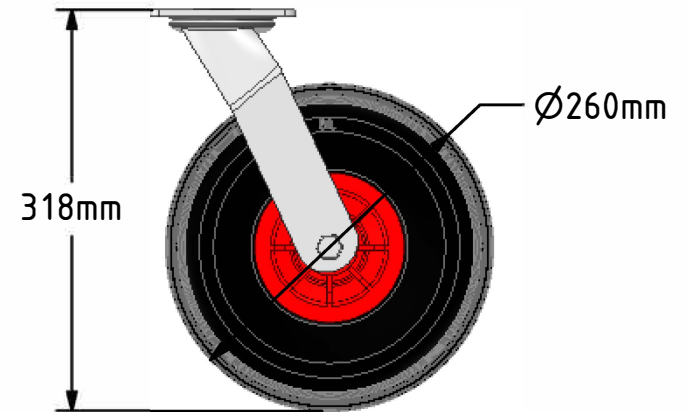
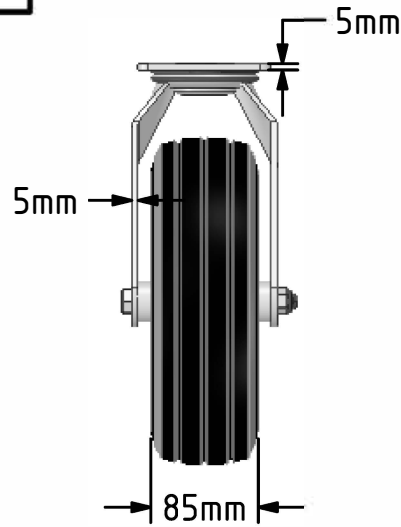
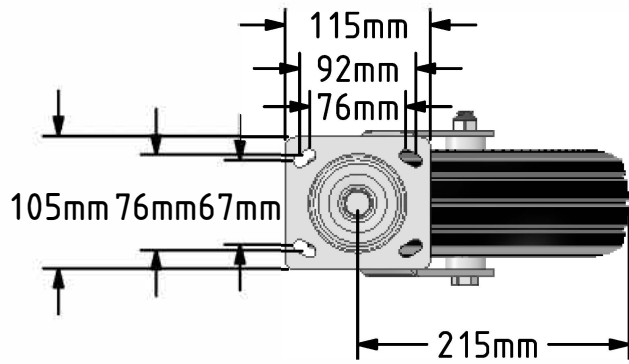

Description:
BZFPC260PPUB

Fabricated swivel castor with a top plate fixing fitted with a black ribbed pattern puncture proof tyre red polypropylene centred wheel with roller bearing. Wheel diameter 260, tread width 85mm, overall height 318mm, plate size 115mm x 105mm, hole centres 92mm x 67mm or 76mm x 76mm. Load capacity 120kg.



	NAME	DATE
DRAWN	Matt	15/11/16
APPROVED BY	Tim W	15/11/16
SCALE	1:6	15/11/16
WEIGHT	3.678kg	15/11/16

UNLESS OTHERWISE SPECIFIED DIMENSIONS ARE IN MILLIMETRES

Unspecified Tolerances
Machining ± 0.25mm
Fabrication ± 1mm

Sinclair & Rush Ltd.

TITLE

CPNW12

SIZE

DWG NO.

A4

CPNW12_01

REV

1

FILE NAME

CPNW12_01.PDF

SHEET 1 OF 1

Sinclair & Rush | 01634 686504 |
sales@sinclair-rush.co.uk

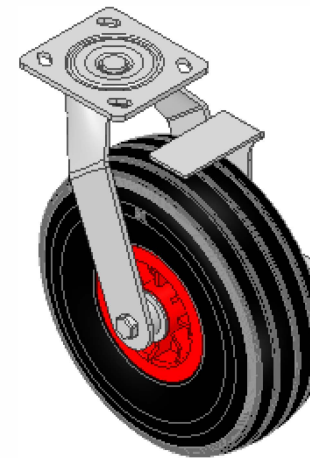
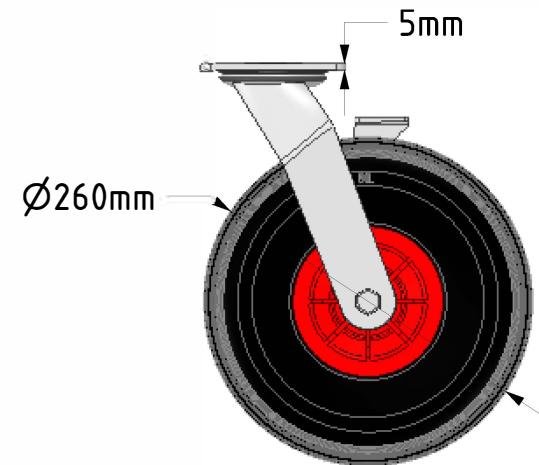
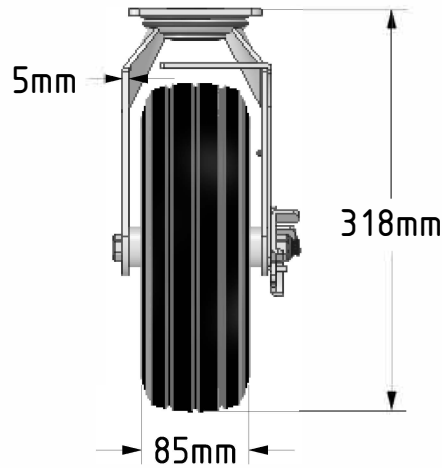
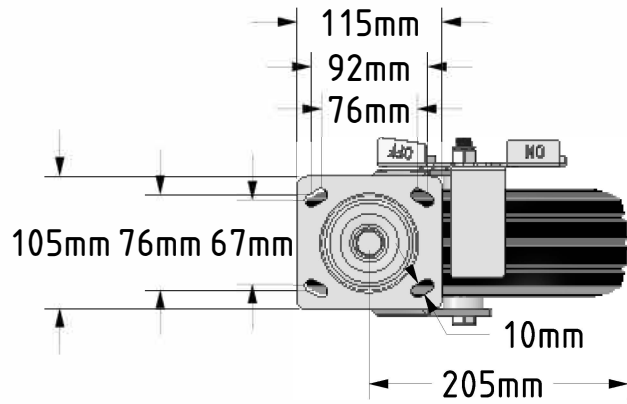

Description:
CPNW13

Fabricated swivel castor with a top plate fixing fitted with a black ribbed pattern puncture proof tyre red polypropylene centred wheel with roller bearing and side fitting wheel brake. Wheel diameter 260, tread width 85mm, overall height 318mm, plate size 115mm x 105mm, hole centres 92mm x 67mm or 76mm x 76mm. Load capacity 120kg.



	NAME	DATE
DRAWN	Matt	15/07/19
APPROVED BY	Chris	15/07/19
SCALE	1:6	15/07/19
WEIGHT	4.703kg	15/07/19

UNLESS OTHERWISE SPECIFIED DIMENSIONS ARE IN MILLIMETRES
Unspecified Tolerances
Machining ± 0.25mm
Fabrication ± 1mm

Sinclair & Rush Ltd.

TITLE		REV
CPNW13		1
SIZE	DWG NO.	
A4	CPNW13_01	
FILE NAME	CPNW13_01.PDF	SHEET 1 OF 1

Sinclair & Rush | 01634 686504 |
sales@sinclair-rush.co.uk

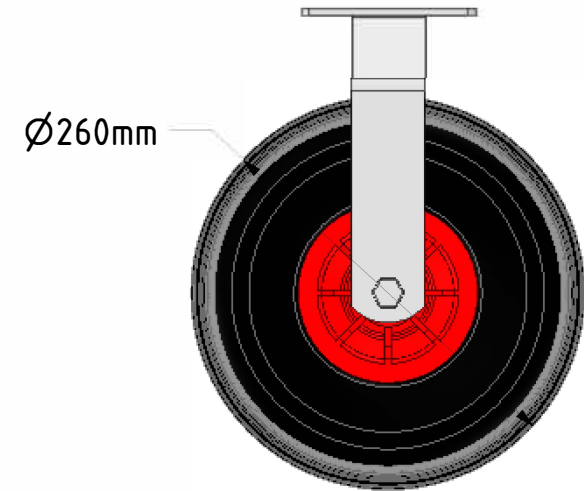
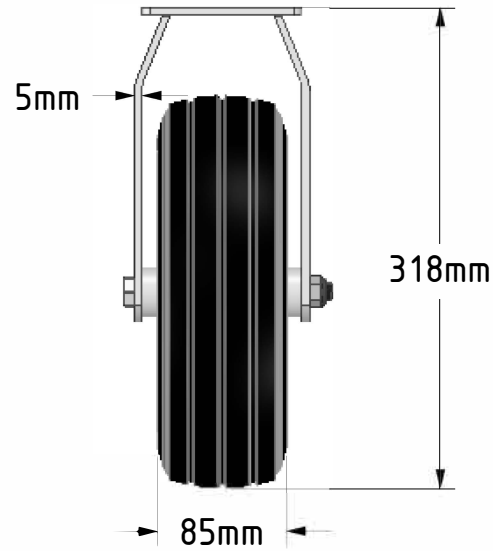
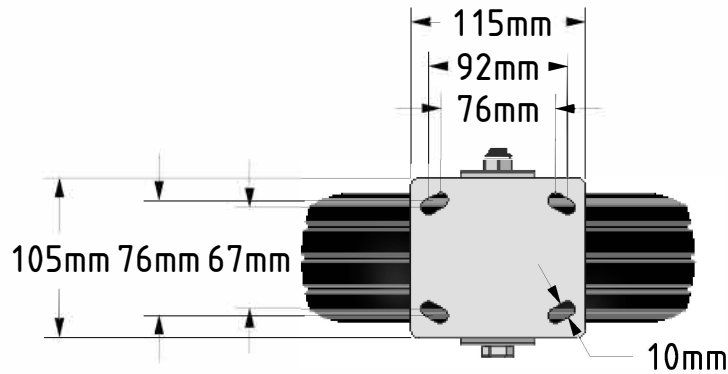

Description:
CPNW14

Fabricated fixed castor with a top plate fixing fitted with a black ribbed pattern puncture proof tyre red polypropylene centred wheel with roller bearing. Wheel diameter 260, tread width 85mm, overall height 318mm, plate size 115mm x 105mm, hole centres 92mm x 67mm or 76mm x 76mm. Load capacity 120kg.



	NAME	DATE	Sinclair & Rush Ltd.	
DRAWN	Matt	12/04/21	TITLE CPNW14	
APPROVED BY				
SCALE	1:5	12/04/21	SIZE DWG NO. REV A4 CPNW14_01 1	
WEIGHT	3.328kg	12/04/21		
UNLESS OTHERWISE SPECIFIED DIMENSIONS ARE IN MILLIMETRES			FILE NAME CPNW14_01.PDF SHEET 1 OF 1	
Unspecified Tolerances Machining ± 0.25mm Fabrication ± 1mm				